



1-21 Grenfell Crescent
Nepean, Ontario K2G 0G3

Phone: (613) 723-0359

Fax: (613) 226-4892

Email: sales@digelair.com

Web Page: www.digelair.com

OCEANAIRE PAC6012

5-TON Portable Conditioner

AIR-COOLED COMMERCIAL RENTAL UNIT



APPLICATION:

These self-contained portable air conditioners should be located inside the room to be cooled.

These self-contained portable air conditioners are designed to be located inside the room to be cooled. The heat is rejected outside of the room by venting the condenser air discharge outside. Typically this is up into the false ceiling space (if the building has a central HVAC system, and it functions as the building return air plenum). The condenser outlet has a flange for connection to flex duct. The unit includes a standard automatic condensate pump.

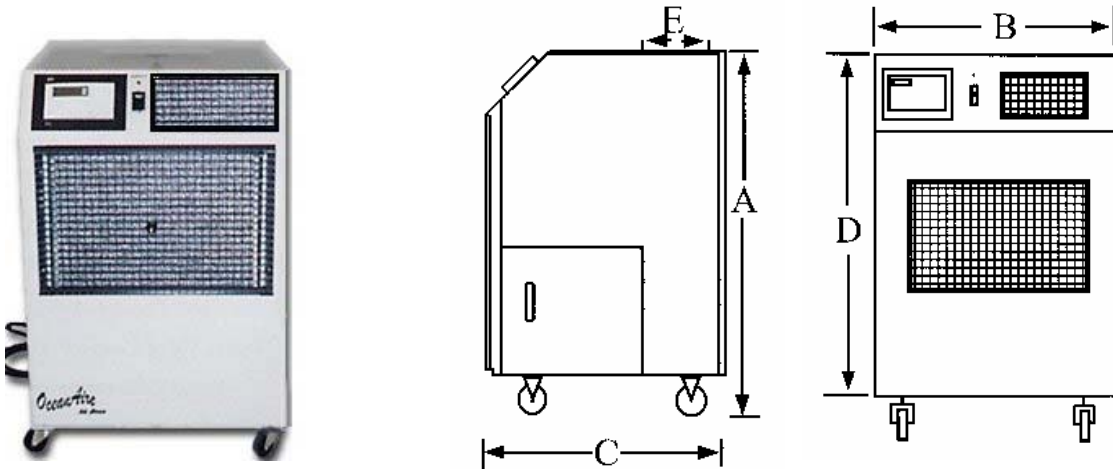

Unit Dimensions (inches)						
Model	A	B	C	D	E	Weight
PAC6012	52.25	28.25	46.0	46.5	16.0 round	540 lbs.

Electrical Specifications				Compressor Data	
Power Supply (Volts)	Current Draw	Wire Size	Circuit Breaker	Type	Refrigerant
208-230/1/60	34.0 amps	#8 AWG	50 amps	Scroll	HCFC-22

Fan Data			Duct Data		
Section	Fan Type	Air Flow	Section	Duct Size	Max. Length
Evaporator	Direct drive	2200	Evaporator	n/a	n/a
Condenser	Direct drive	2900	Condenser	16	100 (.50 esp)